

FlowCon SM

Pressure Independent Control Valves
15-40 mm / 1/2"-1 1/2"



SPECIFICATIONS

Valve:

Static pressure:	2500 kPa / 360 psi
Ambient temperature:	-10°C to +50°C / +14°F to +122°C
Media temperature:	-20°C to +120°C / -4°F to +248°C
Material:	
- Housing and covers:	Forged brass ASTM CuZn40Pb2
- Union end connections:	Brass alloy
- Metal components (internal):	Stainless steel
- Stem seal and O-rings:	EPDM
- Diaphragm:	Hydrogenated acrylonitrile-butadiene-rubber
Stroke:	2160°
Maximum close off pressure:	600 kPa / 87 psi
Maximum operational ΔP :	320 kPaD / 46 psid
Control characteristic:	Linear rotation
Control range:	1:1000 / IEC 60534
Rangeability:	>100:1
Turn down ratio:	228:1
Shut-off leakage:	ANSI / FCI 70-2 206 / IEC 60534-4 – Class IV
Flow rate range:	0.176-2.34 l/sec / 2.78-37.1 GPM
End connection:	Union end connections ISO or NPT
Body taps:	1/4" ISO

SPECIFICATIONS

FlowCon Actuator:

FlowCon SM.0.0.0.3, SM.0.0.0.4, SM.0.0.0.5 (with BACnet) and SM.0.0.0.6 (with BACnet) actuators¹

Supply voltage:	22-26V AC, 50/60 Hz or 28-32V DC
Type:	Electrical, Bi-directional synchronous motor
Power consumption:	12VA For failsafe versions: 25VA (peak)
Control signal:	Analog 0(2)-10V DC or 0(4)-20mA and digital 3-point-floating or 2-position
Resolution:	1:1000 (0-10V analog) and 1:800 (2-10V analog)
Feedback:	Linear signal Auto (equal to analog control signal), 0-10V DC, 2-10V DC or 4-20mA
Control mode:	Linear rotation (other control modes do not apply to SM.1 and SM.2)
Failsafe function:	Yes (on SM.0.0.0.4 and SM.0.0.0.6)
Manual override:	Yes
Position indicator:	No
Operation time:	190 sec (from closed to fully open valve)
Ambient temperature:	-10°C to +50°C / +14°F to +122°F
Humidity rating:	5..95% rH, no condensation
Protection:	IP54 including upside-down mounting
CE conformity:	EN 60730, class II
Housing material:	UL94 V0-rated plastic
Programming:	Programming of all settings on interface with buttons and display or via BACnet
Cable:	Fixed, 5 wires x 0.80 mm ² , halogen free, 1 meter Fixed, 5 wires x AWG18, halogen free, 3.2 ft Additional for BACnet versions: Fixed, 3 wires x 0.80 mm ² , halogen free, 1 meter Fixed, 3 wires x AWG18, halogen free, 3.2 ft
Calibration:	Automatic at startup
Valve-actuator coupling:	Easy snap coupling
BACnet device profile:	BACnet Application Specific Controller (B-ASC) type server
BACnet protocol:	BACnet Master Slave/Token passing (MS/TP)
BACnet baud rates supported:	9600, 19200, 38400 and 76800
BACnet services (BIBBS) supported:	DS-RP-B, DS-WP-B, DM-DOB-B, DM-DOB-B and DM-DCC-B

Note 1: FlowCon warranty is voided using other actuators than supplied or recommended by FlowCon International.

DIMENSIONS AND WEIGHT (NOMINAL)

Model no.	Valve size	L	H	H1	End connections C ²			Weight ³
					ISO Female	ISO Male	Sweat	
	mm (in)	mm (in)	mm (in)	mm (in)	mm (in)	mm (in)	mm (in)	kg (lb)
SM.1.1	15 (1/2)	108 (4.25)	59 (2.32)	185 (7.28)	22 (0.87)	24 (0.95)	20 (0.79)	2.9 (6.4)
	20 (3/4)				22 (0.87)	25 (0.99)	20 (0.79)	
	25 (1)				-	39 (1.54)	22 (0.87)	
SM.2.1	25 (1)	149 (5.87)	63 (2.48)	235 (9.25)	35 (1.38)	40 (1.57)	34 (1.34)	4.6 (10.1)
	32 (1 1/4)				33 (1.30)	40 (1.57)	34 (1.34)	
	40 (1 1/2)				33 (1.30)	42 (1.65)	-	

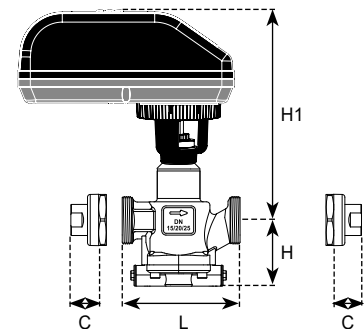

Note 2: Add end connection length to body length.

Note 3: Weight includes valve and actuators.

MODEL NUMBER SELECTION

SM . . . 1

Insert body size:
1=DN15-25 / 1/2"-1" **2**=DN25-40 / 1"-1 1/2"

Insert dP control range:
1=standard

Insert p/t plug requirements:
B=pressure/temperature plugs (standard) **P**=taps plugged

Insert actuator selection:
3=display standard (SM.0.0.0.3) **4**=display and failsafe (SM.0.0.0.4)
5=display and BACnet (SM.0.0.0.5) **6**=display, BACnet and failsafe (SM.0.0.0.6)

Insert inlet x outlet union end connections:

Body model and size	Female threaded	Male treaded	Sweat	
SM.1.1, 15-25 mm, 1/2"-1"	E = 15 mm / 1/2" F = 20 mm / 3/4"	H = 15 mm / 1/2" I = 20 mm / 3/4" J = 25 mm / 1"	K = 15 mm L = 18 mm M = 22 mm	O = 1/2" R = 3/4" U = 1"
SM.2.1, 25-40 mm, 1"-1 1/2"	G = 25 mm / 1" P = 32 mm / 1 1/4" Q = 40 mm / 1 1/2"	J = 25 mm / 1" S = 32 mm / 1 1/4" T = 40 mm / 1 1/2"	N = 28 mm W = 35 mm	V = 1 1/4" W = 1 1/2"

Insert connections standard:
I=ISO **N**=NPT

Example: SM.2.1.B.1.Q.Q.3=SM 25-40 mm (1"-1 1/2") body with p/t plugs, standard display actuator and 40 mm (1 1/2") ISO female threaded end connections.

WIRING INSTRUCTION

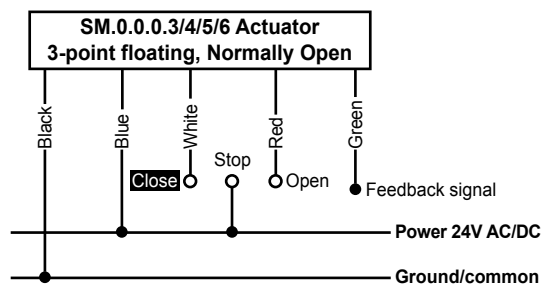
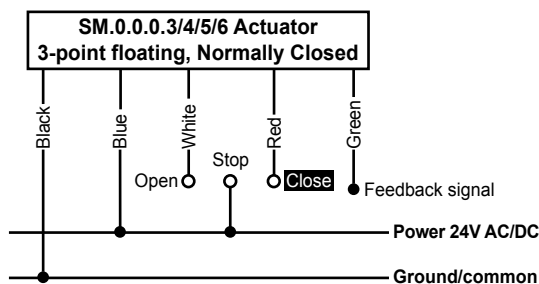
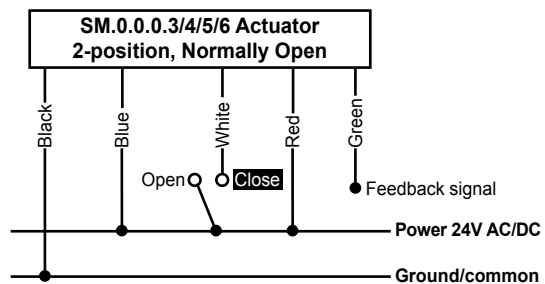
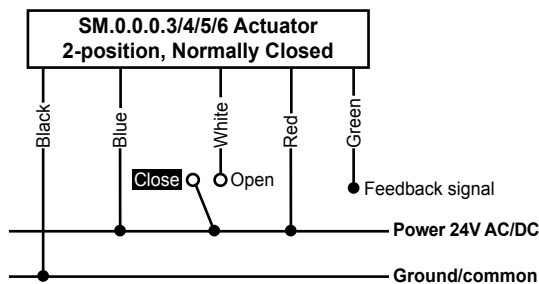
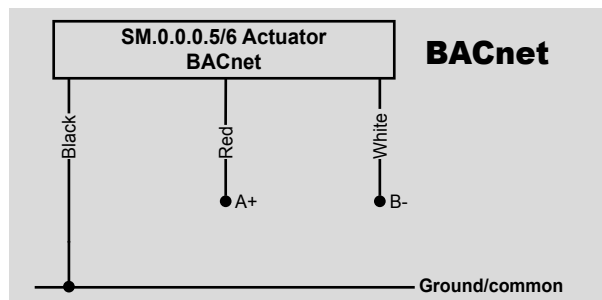
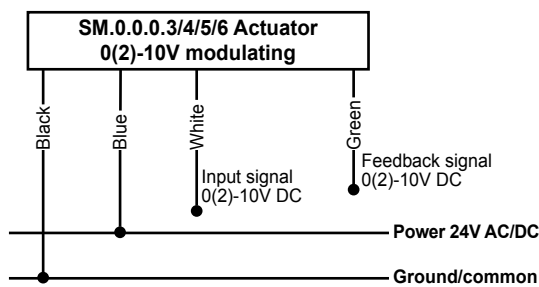

Note: If feedback signal is not required, leave green wire detached.

DESCRIPTION

The SM series is a range of self-balancing dynamic flow control valves that are pressure independent and 2-way and ready to accept digital or analog input signals. Each valve has an adjustable maximum flow rate setting to enable flow limitation to and balancing of the coil or zone which the valve is controlling.

All SM actuators are microprocessor based with a self-calibrating feature. The SM actuator range includes standard incl. feedback, failsafe and BACnet. All SM actuators are programmable and with display. The SM actuators accept analog 0(2)10V DC or 0(4)-20mA as well as digital 3-point floating or 2-position input signals and work with control mode of linear rotation.

The smaller range of SM-valves are all designed for double union piping connection. They are available in two different valve body sizes with a range of end connections. All shall have snap connection for fast mounting of actuator.

FLOW RATE TABLE

Model no.	Valve size		Control range		Lowest settable max flow			Turn down ratio lowest max flow	Highest settable max flow			Turn down ratio highest max flow
	mm	inch	kPaD	psid	l/sec	l/hr	GPM		l/sec	l/hr	GPM	
SM.1.1	15	1/2	32-320	4.6-46	0.176	633	2.78	38:1	0.685	2470	10.9	228:1
	20	3/4										
	25	1										
SM.2.1	25	1	40-320	5.8-46	0.513	1850	8.13		2.34	8420	37.1	
	32	1 1/4										
	40	1 1/2										

Accuracy: Greatest of either $\pm 5\%$ of controlled flow rate or $\pm 2\%$ of maximum flow rate.

FLOW RATE SETTINGS⁴

Maximum Flow Rate					
DN15-DN25 · 1/2"-1"			DN25-DN40 · 1"-1 1/2"		
32-320 kPaD · 4.6-46 psid			40-320 kPaD · 5.8-46 psid		
SM.1.1			SM.2.1		
l/sec	l/hr	GPM	l/sec	l/hr	GPM
0.176	633	2.78	0.513	1850	8.13
0.195	702	3.09	0.573	2060	9.08
0.214	770	3.39	0.632	2280	10.0
0.233	838	3.69	0.690	2480	10.9
0.251	902	3.97	0.746	2690	11.8
0.268	964	4.24	0.802	2890	12.7
0.285	1030	4.51	0.856	3080	13.6
0.301	1080	4.77	0.909	3270	14.4
0.317	1140	5.02	0.961	3460	15.2
0.332	1200	5.26	1.01	3640	16.0
0.347	1250	5.50	1.06	3820	16.8
0.362	1300	5.73	1.11	4000	17.6
0.376	1350	5.96	1.16	4170	18.3
0.390	1400	6.18	1.20	4330	19.1
0.403	1450	6.38	1.25	4500	19.8
0.416	1500	6.59	1.29	4660	20.5
0.428	1540	6.78	1.34	4810	21.2
0.440	1580	6.97	1.38	4970	21.9
0.452	1630	7.16	1.42	5120	22.5
0.463	1670	7.33	1.46	5260	23.2
0.474	1710	7.51	1.50	5400	23.8
0.485	1750	7.68	1.54	5540	24.4
0.495	1780	7.84	1.58	5680	25.0
0.505	1820	8.00	1.61	5810	25.6
0.515	1850	8.16	1.65	5940	26.2
0.524	1890	8.30	1.69	6070	26.7
0.533	1920	8.44	1.72	6190	27.3
0.542	1950	8.59	1.75	6310	27.8
0.550	1980	8.71	1.79	6430	28.3
0.559	2010	8.86	1.82	6550	28.8
0.567	2040	8.98	1.85	6660	29.3
0.574	2070	9.09	1.88	6770	29.8
0.582	2100	9.22	1.91	6870	30.3
0.589	2120	9.33	1.94	6980	30.7
0.596	2150	9.44	1.97	7080	31.2
0.603	2170	9.55	1.99	7180	31.6
0.609	2190	9.66	2.02	7280	32.0
0.616	2220	9.76	2.05	7370	32.5
0.622	2240	9.85	2.07	7460	32.9
0.628	2260	9.95	2.10	7550	33.3
0.634	2280	10.1	2.12	7640	33.6
0.639	2300	10.1	2.15	7730	34.0
0.645	2320	10.2	2.17	7810	34.4
0.650	2340	10.3	2.19	7890	34.8
0.655	2360	10.4	2.22	7970	35.1
0.661	2380	10.5	2.24	8050	35.5
0.667	2400	10.6	2.26	8130	35.8
0.671	2420	10.6	2.28	8200	36.1
0.676	2430	10.7	2.30	8280	36.4
0.680	2450	10.8	2.32	8350	36.8
0.685	2470	10.9	2.34	8420	37.1

Accuracy: Greatest of either $\pm 5\%$ of controlled flow rate or $\pm 2\%$ of maximum flow rate.

Note 4: Above indicates selectable maximum flow rates defining the flow through the valve at maximum control signal, normally 10V.
Each valve includes up to 1000 positions between the selected max.flow and closed valve with control signal selected to 0-10V.

CONTROL CURVE

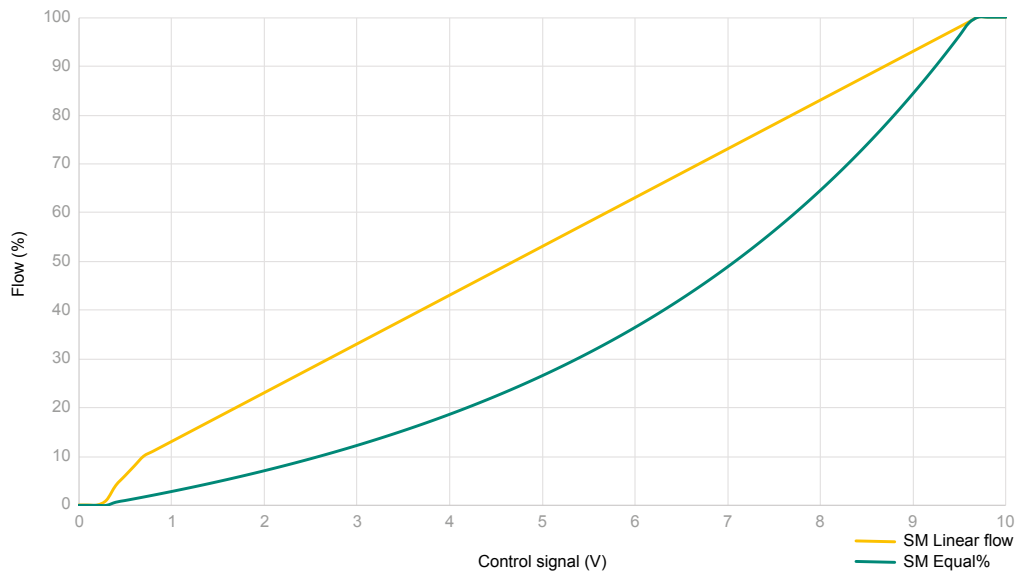

GENERAL SPECIFICATIONS

1. PRESSURE INDEPENDENT DYNAMIC CONTROL VALVES – FLOWCON SM

- 1.1. Contractor shall install pressure independent dynamic control valves where indicated in drawings.
- 1.2. Valve shall be an electronic, dynamic, modulating, 2-way pressure independent control device.
- 1.3. Valve shall accurately control flow, independent of system pressure fluctuation.

2. VALVE ACTUATOR

- 2.1. Valve-actuator coupling shall be snap coupling for fast mounting and de-mounting.
- 2.2. Actuator housing shall be rated to IP54 including upside-down mounting.
- 2.3. Actuator shall be driven by a 24V AC/DC motor and shall accept 0(2)-10V, 0(4)-20mA, 3-point floating or 2-position control signal.
- 2.4. Actuator control mode shall be linear rotation.
- 2.5. Actuator shall be capable of providing linear feedback signal to the control system. Feedback signal shall be selectable to Auto (equal to input signal), 4-20mA, 0-10V DC or 2-10V DC.
- 2.6. Automatic calibration of valve position shall be standard.
- 2.7. Actuator shall include buttons for external programming of all settings.
- 2.8. Actuator display showing current valve flow, maximum valve flow, input signal, feedback signal, operational direction and control mode shall be standard.
- 2.9. Optional failsafe versions shall be available. Failsafe versions shall be able to operate valve to either open (max. setting) or closed position from any position in case of power failure.
- 2.10. Optional BACnet versions shall be available. BACnet versions shall provide remote setting and control of actuator.

3. VALVE HOUSING

- 3.1. Housing shall consist of forged brass ASTM CuZn40Pb2 rated at no less than 2500 kPa (360 psi) static pressure and +120°C (+248°F).
- 3.2. Housing shall be permanently marked to show direction of flow.
- 3.3. Housing shall be double union end construction with a range of pipe connections available for appropriate pipe size.
- 3.4. Dual pressure/temperature test plugs for verifying accuracy of flow performance shall be standard on all valve sizes.

4. FLOW REGULATOR / AUTOMATIC BALANCING UNIT

- 4.1. Maximum flow setting shall be adjustable to minimum 51 different settings within the range of the valve size.
- 4.2. Flow regulation unit shall be manufactured of stainless steel and hydrogenated acrylonitrile-butadiene-rubber and shall be capable of controlling flow within $\pm 5\%$ of controlled flow rate of $\pm 2\%$ of maximum flow rate.
- 4.3. Flow regulation unit shall be accessible for change-out or maintenance.

APPLICATION AND SCHEMATIC EXAMPLE

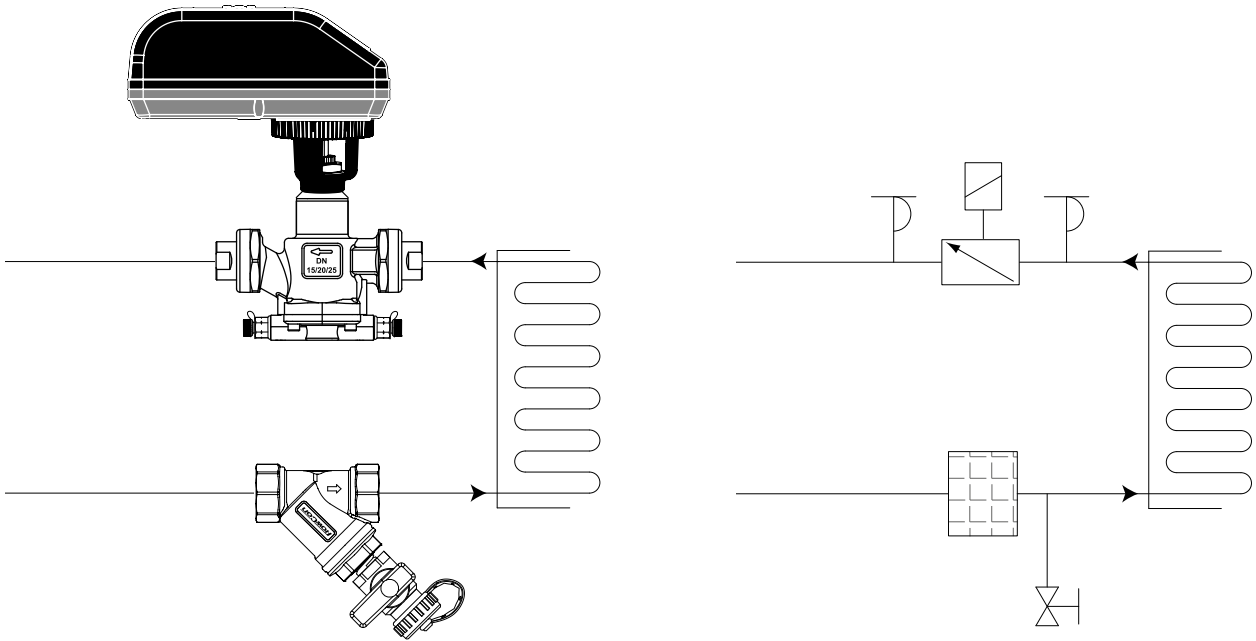

UPDATES

For latest updates please see www.flowcon.com

FlowCon International can accept no responsibility for possible errors in any printed material.
All rights reserved.